



Hysteresis Based On Artificial Intelligence Techniques of Six Sectors DTC with Voltage Zero for Induction Machine

H. Benbouhenni

Département de Génie Électrique, Ecole Nationale Polytechnique d'Oran Maurice Audin (ENPO-MA), BP : 1523 El M'nouer, Oran, Algeria.

*Corresponding author. Tel.: + 213 663956329. habib0264@gmail.com

Abstract. In this paper, a novel structure of DTC with voltage zero based on intelligent hysteresis is proposed. This intelligent hysteresis is likely to be used for reduced of torque, flux ripples, and THD (Total Harmonic Distortion) of stator current. The proposed structure is analyzed and then compared with DTC conventional of the induction machine. Comparison depicts the proposed DTC control superiority over the conventional DTC control. In this proposed structure, the classical hysteresis of torque replace by the fuzzy controller, and hysteresis of flux replace by a neural controller. The control scheme is implemented using Matlab/Simulink. The simulation results are in good agreement which shows the effectiveness of the proposed DTC control.

Keywords. DTC, Induction machine, Fuzzy controller, Neural controller, Classical hysteresis, Voltage zero, Intelligent hysteresis.

INTRODUCTION

Among all types of AC machine, the induction machine (IM) is most commonly used in industry. These machines are very economical, rugged and reliable and are available in the ranges of fractional horse power (FHP) to multi megawatt capacity (More et al., 2015). In normal reference frames, the torque and flux of an IM drive are coupled together and hence independent control becomes difficult (Surekha et al., 2015).

The introduction of field oriented control (FOC) in the 1970s made a huge turn in the control of induction motor drive. FOC uses frame transformation to decouple the torque and flux components of the stator current (More et al., 2015). Therefore the performance of IM becomes similar to that of the dc motor. The implementation of this system, however, is complicated and is well known to be highly sensitive to parameter variations due to the feed forward structure of its control system (Allirani et al., 2012).

A new control method called direct torque control (DTC) has been created. DTC is characterized by his simple implementation and robustness (Mouna et al., 2016). Figure1 shows a DTC of the induction machine. In DTC controlled IM drives, it is possible to control directly the stator flux linkage and the electromagnetic torque by the selection of an optimum inverter switching state. The selection of the switching state serves two functions: the flux and the torque errors within their respective hysteresis bands and to obtain the fastest torque response and highest efficiency at every instant (Mahfouz, 2012).

The disadvantages of conventional DTC include notable torque, flux and current pulsations and non-constant switching frequency operation. The advantages allotted to traditional techniques DTC (dynamic, robustness, facilitated implementation) nevertheless are counterbalanced by the use of a sampled hysteresis comparator; by principle, the comparator led functioning at variable frequency which increases the risks of mechanical excitation or acoustic resonances, and in addition, sampling at finished frequency results by an exceeding pseudo-random of the hysteresis band. These two factors contribute to making the contents harmonic of the various output signals not easily foreseeable (Boudana et al., 2012).

This paper proposes new intelligent hysteresis controllers into DTC strategy of IM drive. Intelligent hysteresis improves the overall performance of DTC controlled system. The paper proposes a new hysteresis controllers based on fuzzy logic and neural networks. The fuzzy controller for flux hysteresis comparator and neural controller for torque hysteresis comparator. The proposed strategy is characterized by low inverter switching losses, leading to reduced torque ripples.

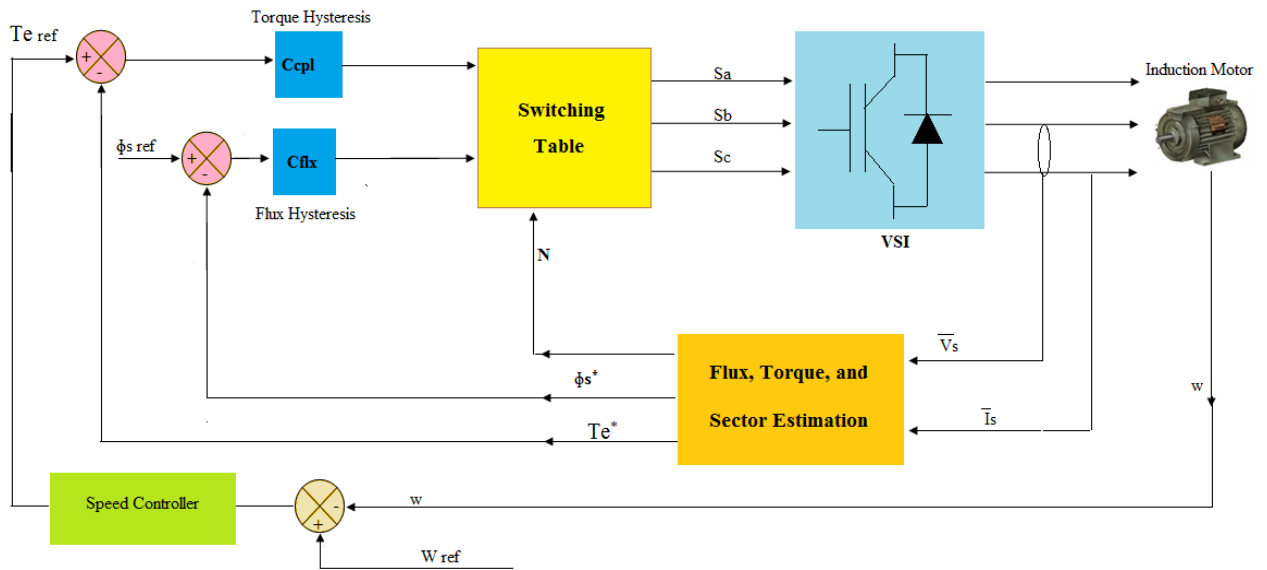

Fig. 1. Direct torque control scheme.

INDUCTION MACHINE MODEL

The model of IM in α, β reference can be written in the following from (Sebti, 2013; Mokhtari, 2016):

$$\dot{x} = A.X + B.U \quad (1)$$

Such as:

$$X = \begin{bmatrix} i_{\alpha s} \\ i_{\beta s} \\ \Phi_{\alpha s} \\ \Phi_{\beta s} \end{bmatrix}; U = \begin{bmatrix} V_{\alpha s} \\ V_{\beta s} \end{bmatrix} \quad (2)$$

$$A = \begin{bmatrix} \lambda & -w_r & \frac{1}{\sigma.L_s.T_r} & \frac{w_r}{\sigma.L_s} \\ w_r & \lambda & -\frac{w_r}{\sigma.L_s} & \frac{1}{\sigma.L_s.T_r} \\ -R_s & 0 & 0 & 0 \\ 0 & -R_s & 0 & 0 \end{bmatrix}; B = \begin{bmatrix} \frac{1}{\sigma.L_s} & 0 \\ 0 & \frac{1}{\sigma.L_s} \\ 1 & 0 \\ 0 & 1 \end{bmatrix} \quad (3)$$

With:

$$T_r = \frac{L_r}{R_r}; \sigma = 1 - \frac{M^2}{L_s \cdot L_r}; \lambda = -[\frac{1}{\sigma \cdot T_r} + \frac{1}{\sigma \cdot T_s}]; T_s = \frac{L_s}{R_s}$$

In addition, the electromagnetic torque can be expressed by:

$$T_e = \frac{3}{2} p (\Phi_{\alpha s} i_{\beta s} - \Phi_{\beta s} i_{\alpha s}) \quad (4)$$

The mechanical equation of the motor can be expressed as:

$$J \dot{\Omega} = T_e - T_r - f_r \cdot \Omega_r \quad (5)$$

MODELING OF VSI

Two level three phase inverter is used in this paper. Input of VSI is VDC and output of DTC stator voltage vector. Outputs are V_a , V_b , V_c can be written as (Surekha et al., 2015; Boudjedaimi et al., 2008) :

$$\begin{bmatrix} V_a \\ V_b \\ V_c \end{bmatrix} = \frac{V_{dc}}{3} \begin{bmatrix} 2 & -1 & -1 \\ -1 & 2 & -1 \\ -1 & -1 & 2 \end{bmatrix} \begin{bmatrix} S_A \\ S_B \\ S_C \end{bmatrix} \quad (6)$$

CLASSICAL DTC WITH VOLTAGE ZERO

In 1986 Takahashi and Noguchi proposed the basic concept of the DTC method (Surekha et al., 2015). DTC is a technique used in variable frequency drive for controlling the torque and finally the speed of three phase AC motor drive. It includes calculation of an estimate of the motor's magnetic flux and torque based on the measured voltage and current of the motor (Meha et al., 2014).

The flux and torque are controlled by two comparators with hysteresis. The dynamics torque are generally faster than the flux then using a comparator hysteresis of several levels, is then justified to adjust the torque and minimize the switching frequency average (Mokhtari et al., 2016).

From the measured Voltages and currents of Induction motor, it is easy to estimate the torque, flux and angle (Surekha et al., 2015; Nasir Uddin et al., 2012).

$$\begin{cases} \Phi_{s\alpha} = \int_0^t (v_{s\alpha} - R_s i_{s\alpha}) dt \\ \Phi_{s\beta} = \int_0^t (v_{s\beta} - R_s i_{s\beta}) dt \end{cases} \quad (7)$$

$$\Phi_s = \sqrt{\Phi_{\alpha s}^2 + \Phi_{\beta s}^2} \quad (8)$$

$$\theta_s = \arctg\left(\frac{\Phi_{\beta s}}{\Phi_{\alpha s}}\right) \quad (9)$$

$$T_e = \frac{3}{2} p [\Phi_{\alpha s} i_{\beta s} - \Phi_{\beta s} i_{\alpha s}] \quad (10)$$

A two levels classical voltage inverter can achieve seven separate positions in the phase corresponding to the eight sequences of the voltage inverter (Fig. 2) (Mokhtari et al., 2016).

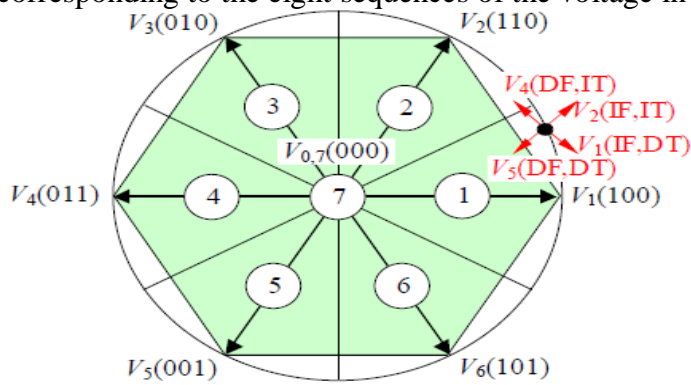

Fig. 2. Different vectors of stator voltages provided by a two levels inverter, (100): (1: inverter switch is ON, 0: for OFF) I(D) F: increase (decrease) of flux magnitude, I(D) T: increase (decrease) of torque.

Table 1 presents the conventional switching table CST and shows the sequences for each position.

Table. 1. Switching table for classical DTC.

N		1	2	3	4	5	6
1	Cflx	2	3	4	5	6	1
	Ccpl	7	0	7	0	7	0
		-1	6	1	2	3	4
0	Cflx	3	4	5	6	1	2
	Ccpl	0	7	0	7	0	7
		-1	5	6	1	2	3

Figures 3 and 4 illustrate the torque and flux comparators, respectively.

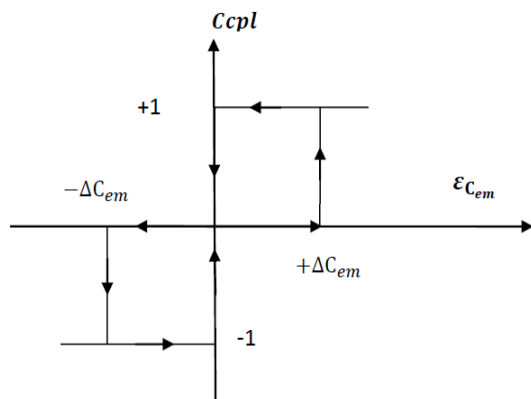

Fig. 3. Torque hysteresis comparator.

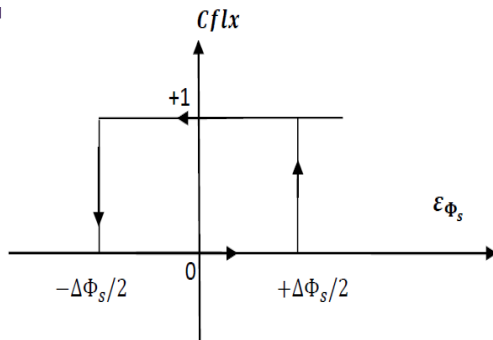

Fig. 4. Flux hysteresis comparator.

INTELLIGENT DTC WITH VOLTAGE ZERO

Fuzzy set theory and fuzzy logic establish the rules of a nonlinear mapping. The use of fuzzy sets provides a basis for systematic ways for the application of uncertain and indefinite models. Fuzzy control is based on a logical system called fuzzy logic which is much closer in spirit to human thinking and natural language than classical logical systems (Mothur et al., 2007).

Neural network (NN) is an interconnected group of artificial neurons that uses a mathematical model or computational model for information processing based on a connectionist approach to computation. In most cases, an ANN is an adaptive system that changes its structure based on external or internal information that flows through the network. Feed forward neural networks are capable of handling nonlinear functions and adapt themselves to variation of parameters due to external disturbances (Sudheer et al., 2016).

The application of Fuzzy logic and artificial neural network attracts the attention of many scientists from all over the world (Boudana et al., 2012). The reason for this trend is the many advantages which the architectures of ANN have over traditional algorithmic methods. Among the advantages of ANN are the ease of training and generalization, simple architecture, the possibility of approximating non-linear functions, insensitivity to the distortion of the network, and inexact input data (Abbou et al., 2009).

In this article, a neural controller is used to replace hysteresis controller of stator flux, and the fuzzy controller is used to replacing hysteresis controller of torque. In order to generate this intelligent hysteresis controller by Matlab/Simulink. The structure of the DTC control of induction machine using intelligent hysteresis controllers is illustrated below in figure 5.

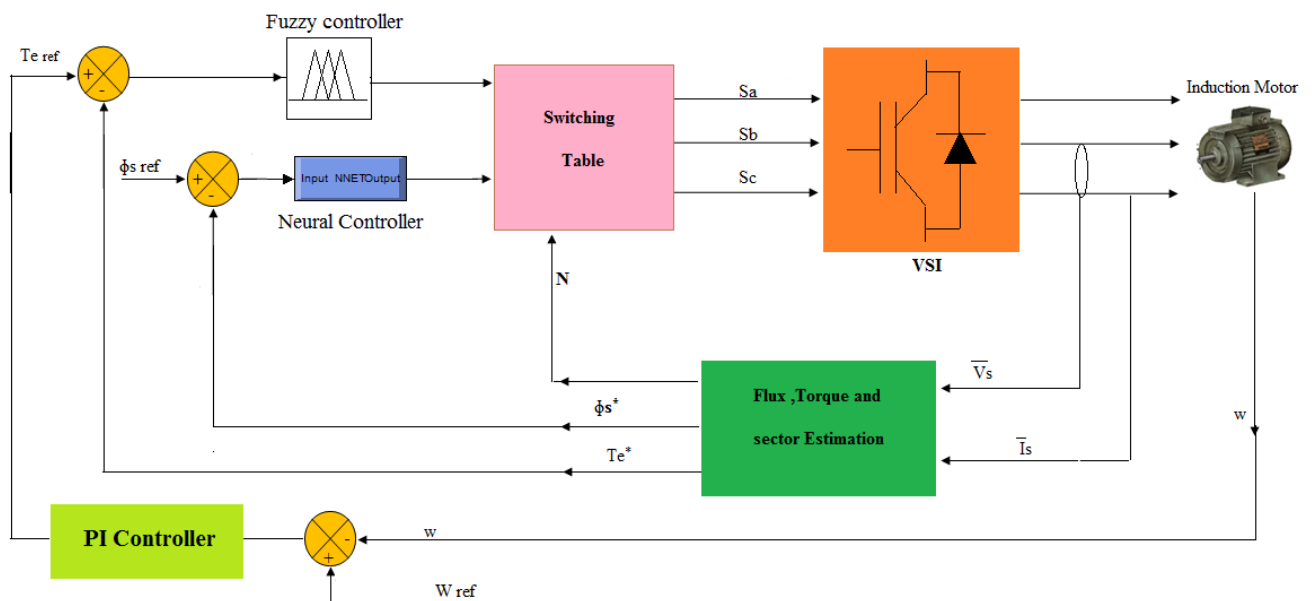

Fig. 5. DTC control of IM using intelligent hysteresis controllers.

Neural controller

Also, in this section, we thought of replacing the hysteresis controller conventional of flux by a neural controller, with the objective of reduced the torque and flux ripples. We selected three linear feed-forward layers with one neuron in the input plus four neurons at the hidden layer, and one neuron in the output layer, with the activation tasks respectively of type “tansig” and “purelin”. The structure of the neural controller of stator flux is illustrated below in figure 6.

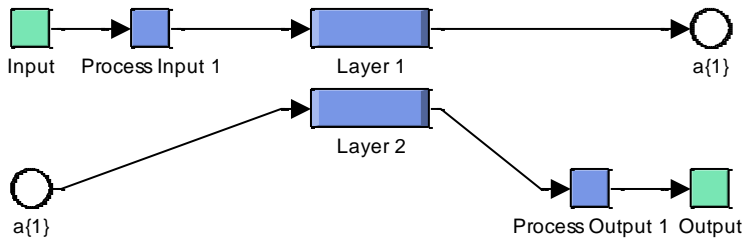

Fig. 6. Structure of neural controller.

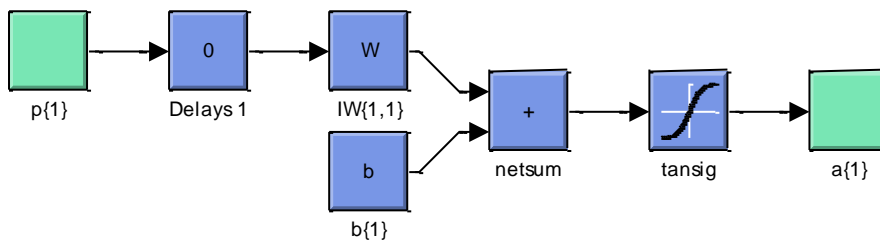

Fig. 7. Layer 1.

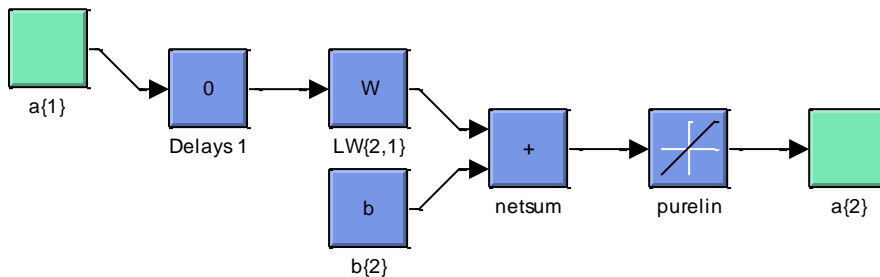

Fig. 8. Layer 2.

Fuzzy hysteresis controller

In this paper, a Mamdani-type FLC is developed to adapt the torque hysteresis band in order to reduce the ripples in the machine-developed torque. In conventional DTC technique, the amplitude of the torque hysteresis band is fixed. However, in this proposed scheme, the FLC controls the upper and lower limits of the torque hysteresis band on the basis of its feedback inputs. The fuzzy systems are universal function approximators. The FLC is used as a nonlinear function approximator producing a suitable change in the bandwidth of the torque hysteresis controller in order to keep the torque ripples minimum (Idir et al., 2013). The block diagram for fuzzy logic based torque hysteresis controller is shown in figure 9.

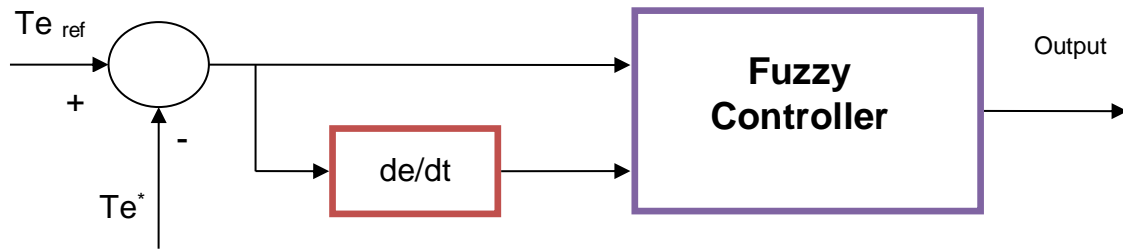

Fig. 9. Fuzzy logic control of torque hysteresis controller.

The fuzzy controller design is based on intuition and simulation. For different values of machine speed and current, the values reducing torque and flux ripple were found. These values composed a training set which is used to extract the table rule $U(e, \Delta e)$ (Idir et al., 2013). The rules sets are shown in Table 2 (Abdelhafidh, 2014).

Table. 2. Fuzzy rules of torque hysteresis controller.

e	NL	NM	NP	EZ	PS	PM	PL
Δe							
NL	NL	NL	NL	NL	NM	NP	EZ
NM	NL	NL	NL	NM	NP	EZ	PS
NP	NL	NL	NM	NP	EZ	PS	PM
EZ	NL	NM	NP	EZ	PS	PM	PL
PS	NM	NP	EZ	PS	PM	PL	PL
PM	NP	EZ	PS	PM	PL	PL	PL
PL	EZ	PS	PM	PL	PL	PL	PL

Figures 10 and 11 shows the membership functions of input and output variables respectively.

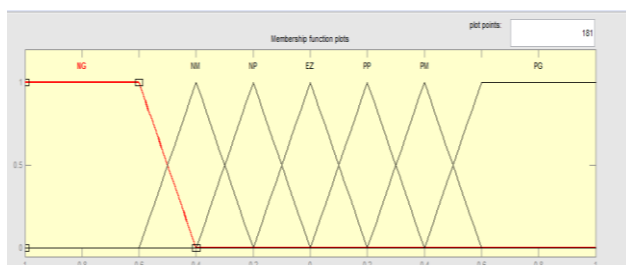

a) Error

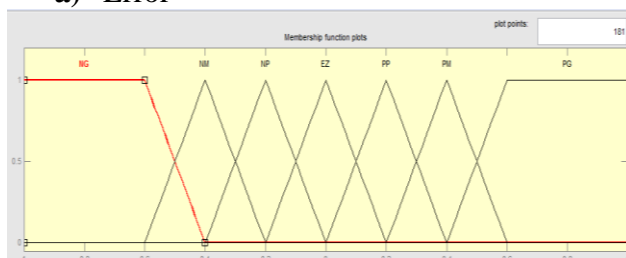

b) Change in error

Fig. 10. Input variables membership functions.

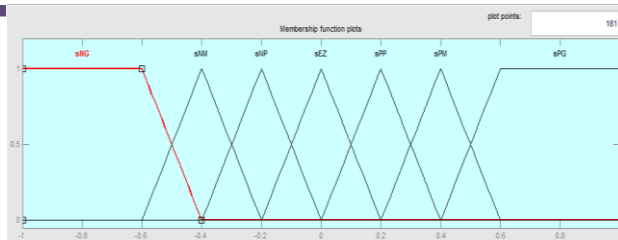
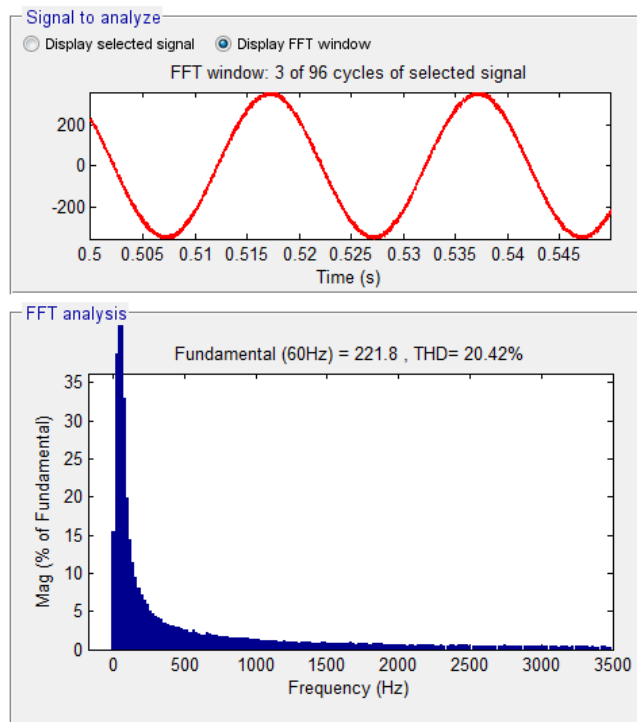

Fig. 11. Output variable membership function.

SIMULATION RESULT

The simulations of the DTC induction machine drive were carried out using the Matlab/Simulink simulation package. A 3-phase, 3 pole, induction motor with parameters of $R_s=0.228\Omega$; $R_r=0.332\Omega$; $L_s=0.0084H$; $L_r=0.0082H$; $L_m=0.0078H$; $J=20 \text{ Kg.m}^2$ are considered.

The simulation results of intelligent DTC of IM are compared with classical DTC. For this end, the controls system was tested under deferent operating conditions such as sudden change of load torque.



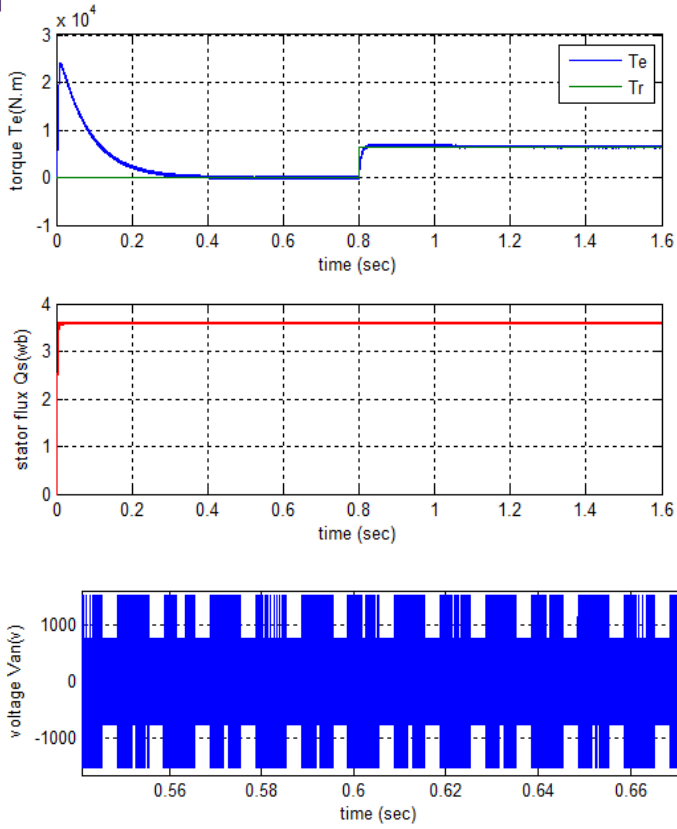
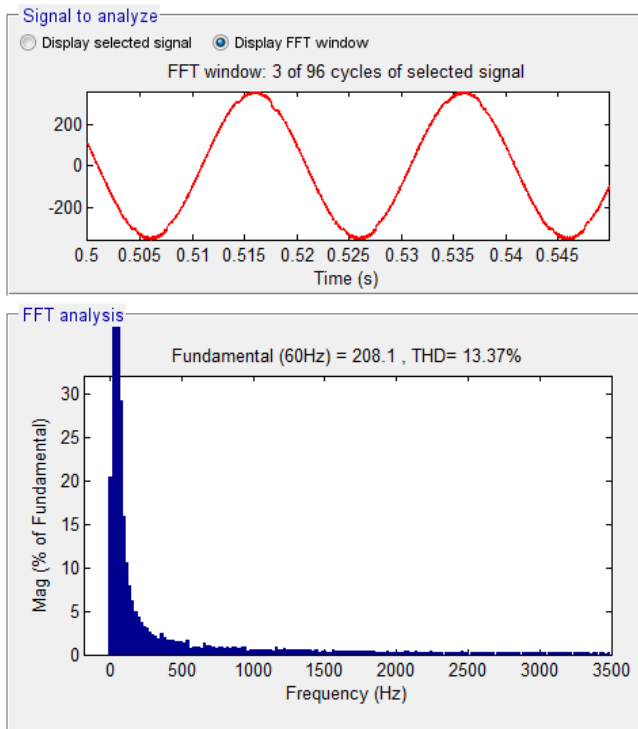

Fig. 12. Performances of classical DTC for IM.



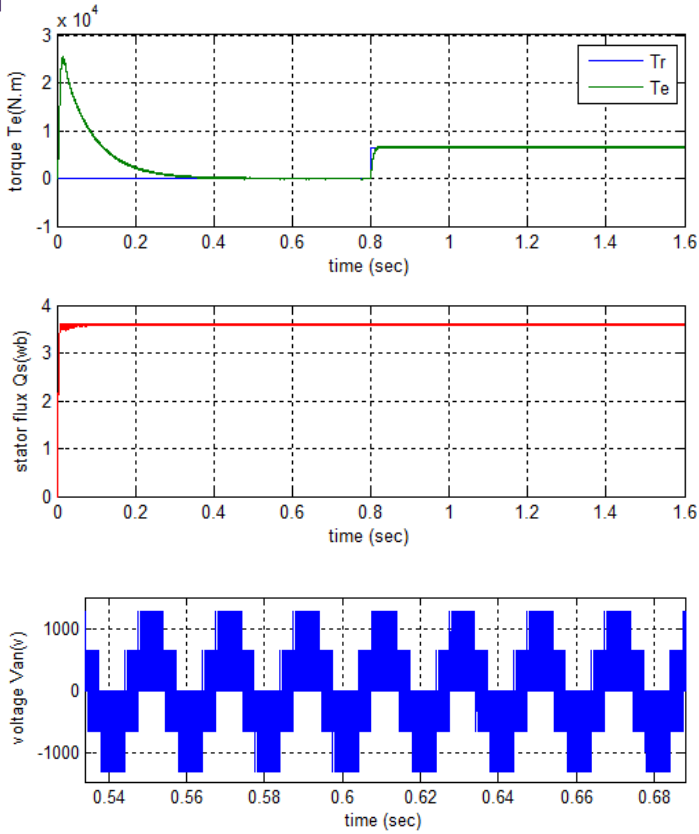
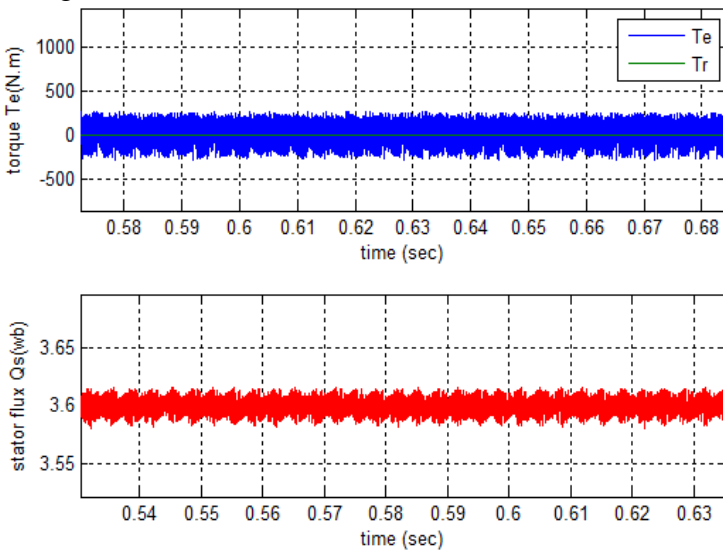

Fig. 13. Performances of classical DTC with intelligent hysteresis controllers.

Figure 14 shows that the DTC with intelligent hysteresis controllers significantly reduces the ripple of the electromagnetic torque and stator flux compared to that of the classical DTC.

The dynamics of the components of the stator flux are not affected by the application of these load guidelines.



a) Classical DTC

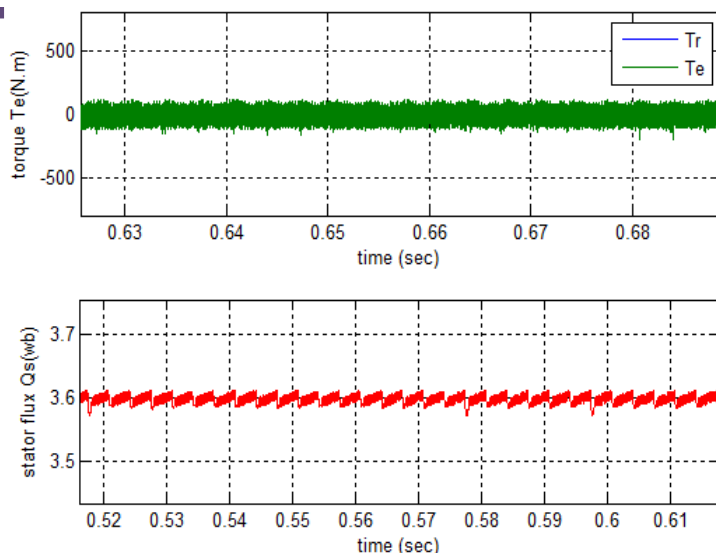

b) Classical DTC with intelligent hysteresis controllers.

Fig. 14. Zoom in the flux and torque.

CONCLUSION

In this paper, the direct torque control of IM using intelligent hysteresis controllers is presented. This controller determines the desired amplitude of torque hysteresis and flux hysteresis band. The intelligent DTC schemes improve considerably the drive performance in terms of reduced torque and flux pulsations. Therefore, intelligent DTC is an excellent solution for general purpose IM drives.

REFERENCES

- Abdelhafidh M., 2014. Stratégies de commande DTC-SVM et DPC appliquées à une MADA utilisée pour la production d'énergie éolienne.
- Abbou A., Mahmoudi H., 2009. Journal of Electrical Systems. 3-5, 64-81.
- Allirani S., Jagannathan V., 2012. International Journal of Computer Applications. 40.
- Boudana D., Nezli L., Telmcani A., Mahmoudi M. O., Tadjine M., 2012. Journal of Electrical Engineering. 63, 133-143.
- Boudjedaimi M., Wira P., Ouled Abdeslam D., Djennoune S., Urban, J. P., 2008. International Conference on Electrical Engineering and its Applications.
- Idir A., Kidouche M., 2013. Proceedings Engineering & Technology. 2, 78-83.
- Mahfouz A. A., 2012. International Journal of Engineering Science and Technology. 4.
- Meha J., Sharma P., Dubey C., 2014. International Journal of Emerging Technology and Advanced Engineering. 4.
- Mokhtari B., Benkhoris M. F., 2016. Journal of Electrical Engineering. 67, 206-211.
- More S., Kulkarni A., 2015. Journal of Electrical and Electronics Engineering. 10, 53-61.
- Mothur H. D., Manjunath H. V., 2007. Journal of Electrical Systems. 3, 124-130.
- Mouna E., Hamid C., El Afia A., 2016. Communications on Applied Electronics. 4.
- Nasir Uddin M., Hafeez M., 2012. IEEE Transactions on Industry Applications. 48, 823-831.
- Sebti B., 2013. Commande par DTC d'un moteur asynchrone apport des réseaux de neurones.
- Sudheer H., Kadad SF., Sarvesh B., 2016. Journal of Electrical Systems. 12, 301-314.
- Surekha V. M., Chandra Sekhar J. N., 2015. Journal of Engineering Research and Applications. 5, 72-78.